

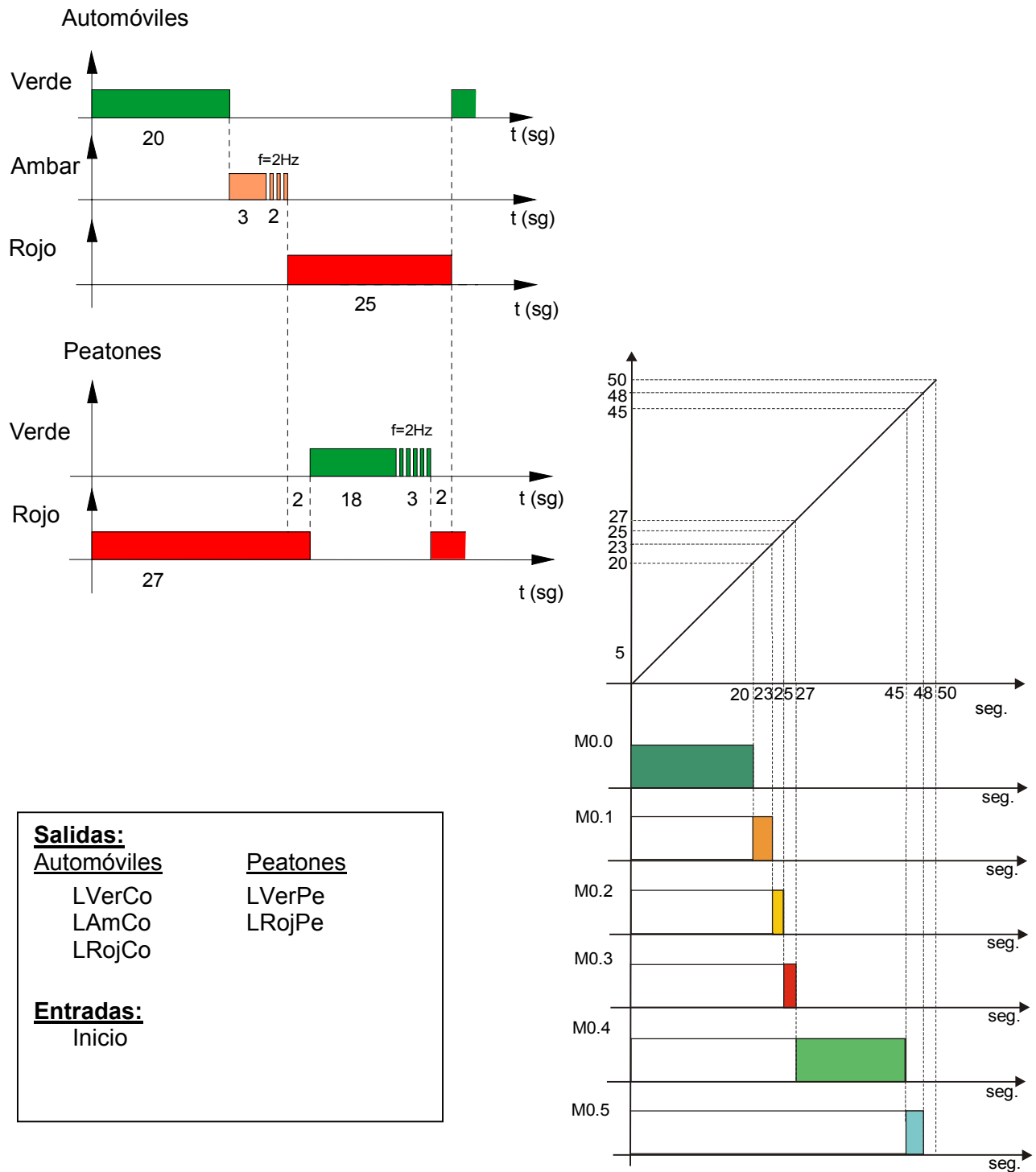

PROBLEMA 3.1

Obtención de una red semafórica mediante un temporizador y funciones de comparación con la siguiente secuencia:

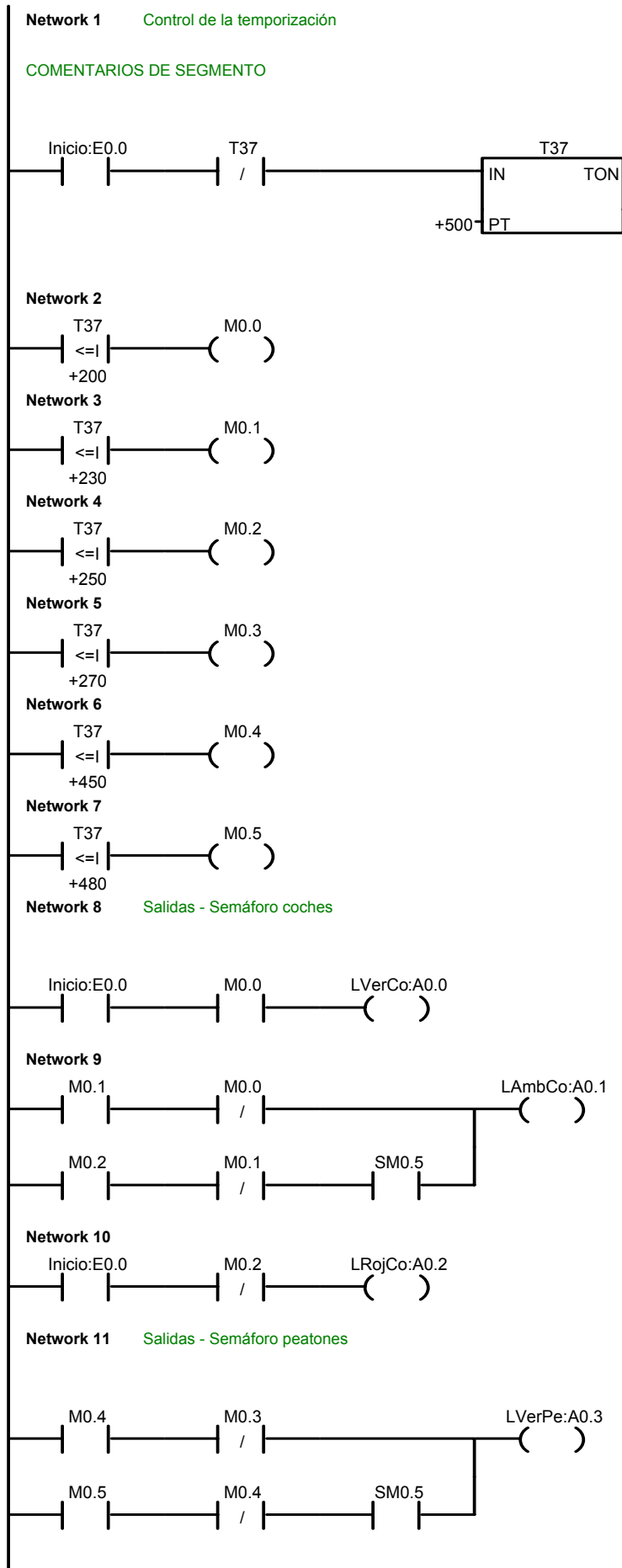



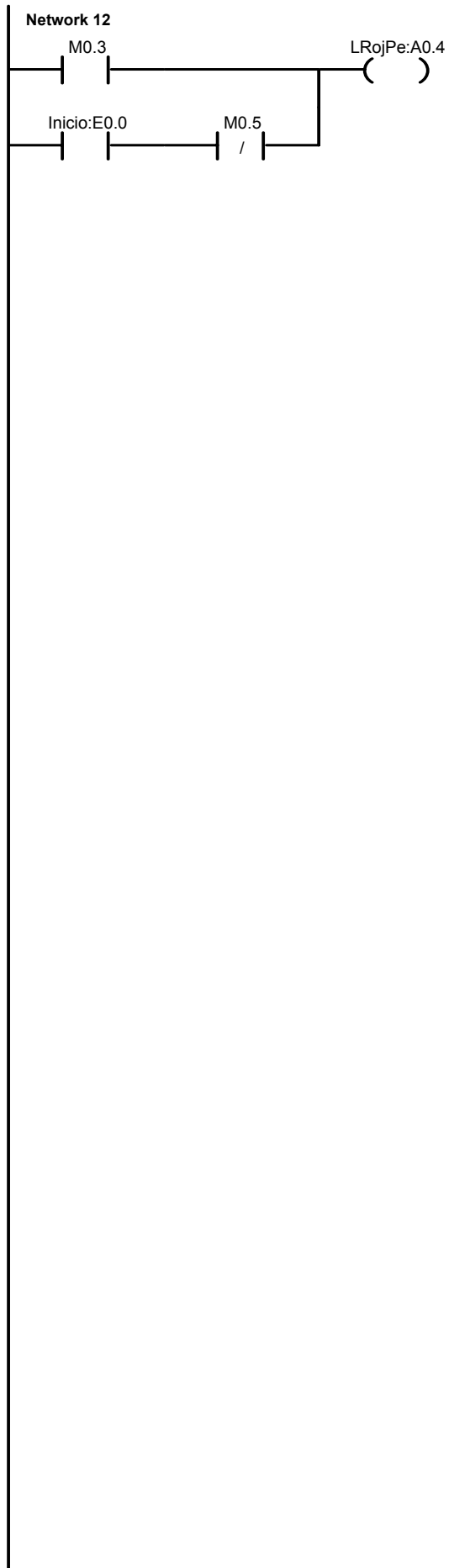

<u>Nombre</u>	<u>Dirección</u>	<u>Comentario</u>
LVerCo	A0.0	
LAmbCo	A0.1	
LRojCo	A0.2	
LVerPe	A0.3	
LRojPe	A0.4	
Inicio	E0.0	