

Ejemplo 1

Lógica cableada a lógica programada

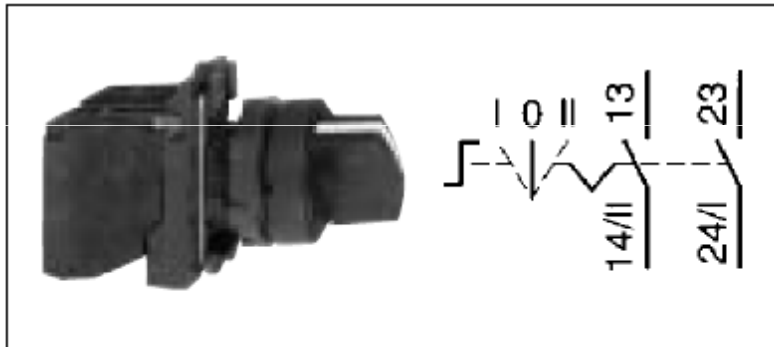

S1: Selector



M1, M2, P1: Pulsadores

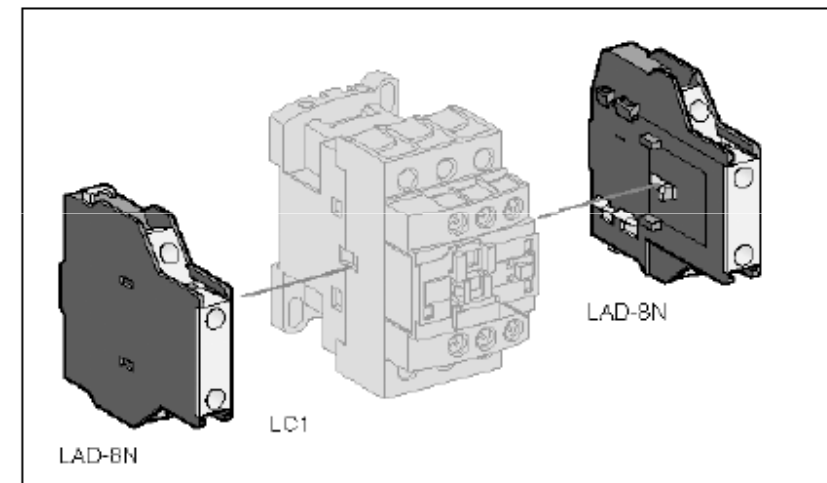
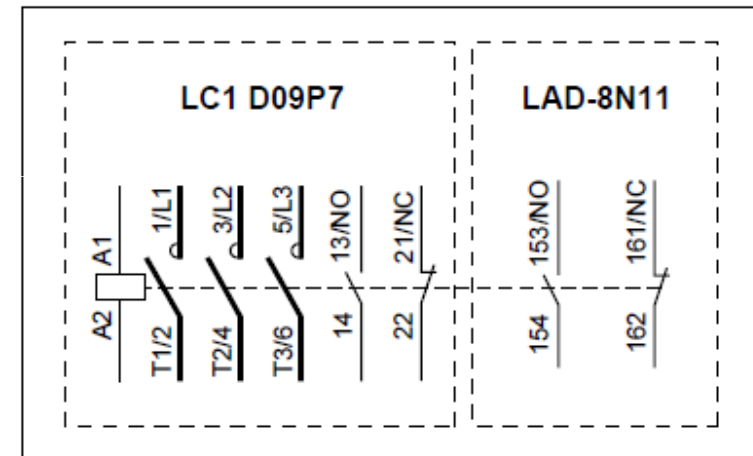
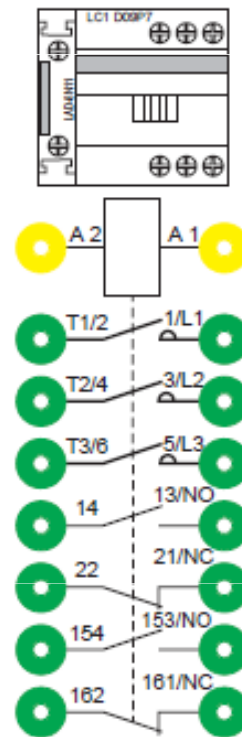
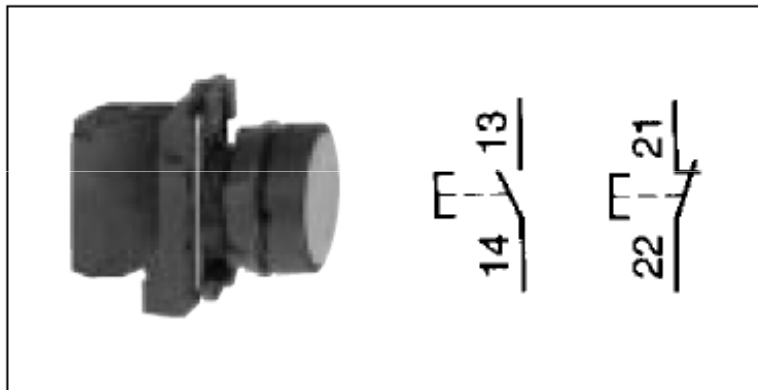



Circuito de mando 1

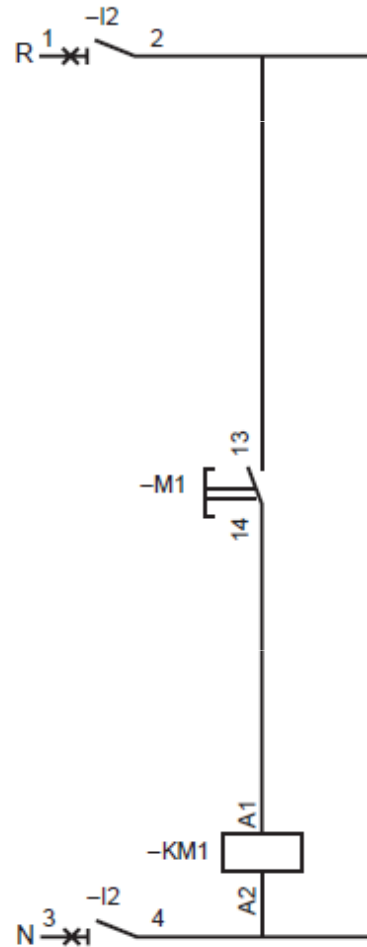

Circuito de mando 2

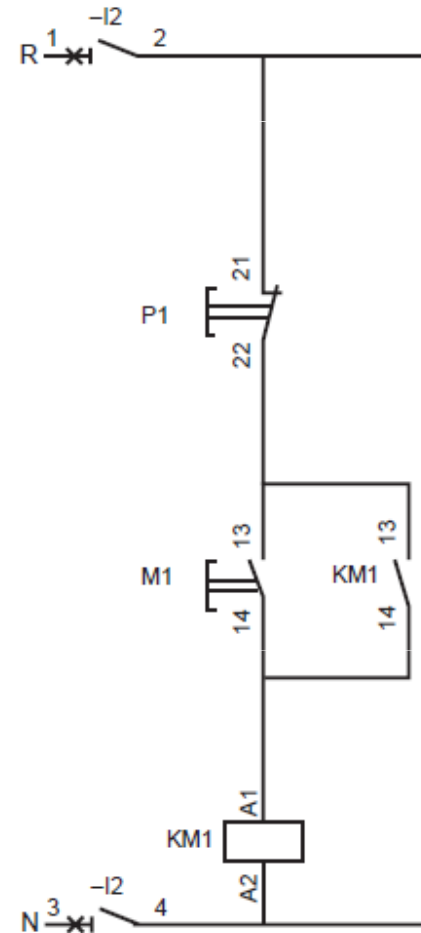

Circuito de fuerza

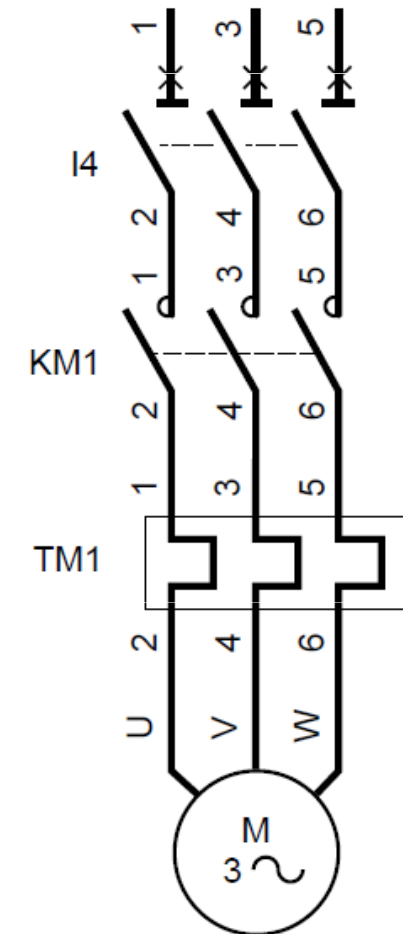



Conexión del autómeta

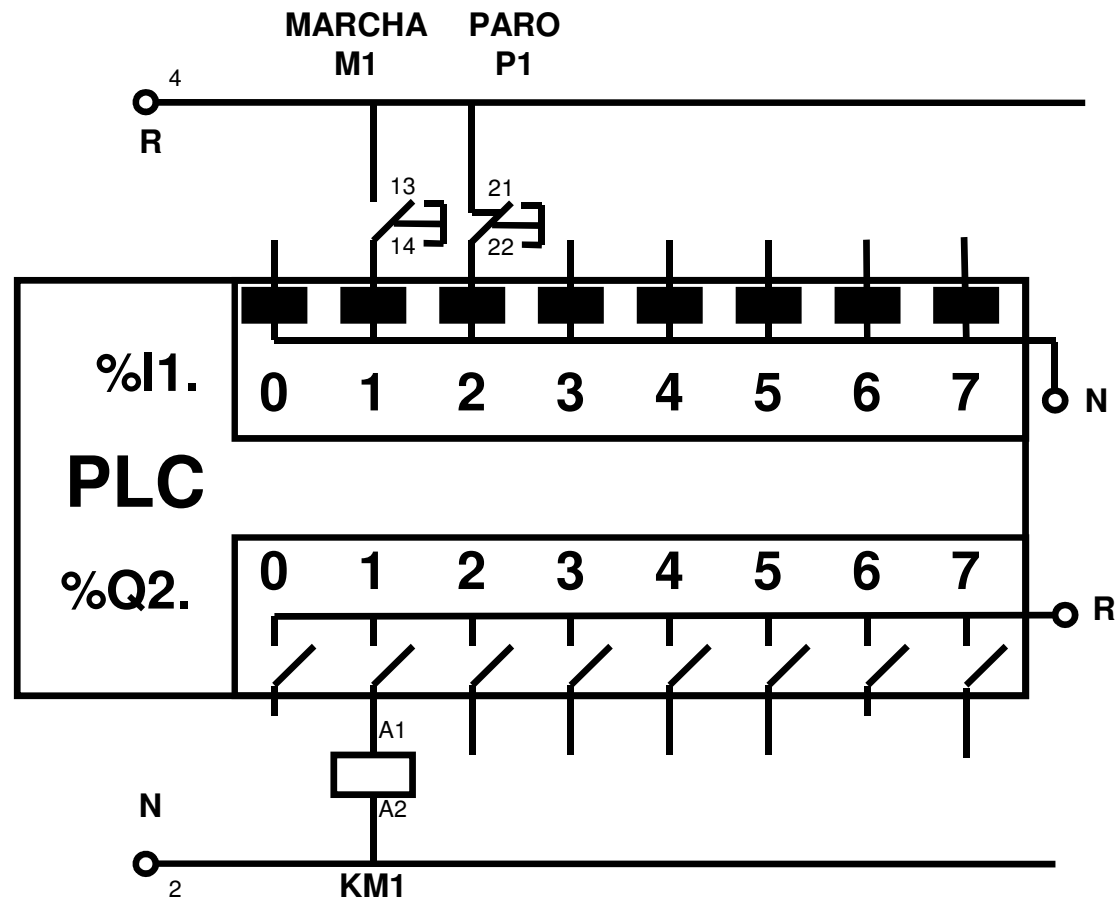



Circuito de mando 1



```
%Q2.1 := %I1.1 ;
```

Circuito de mando 2

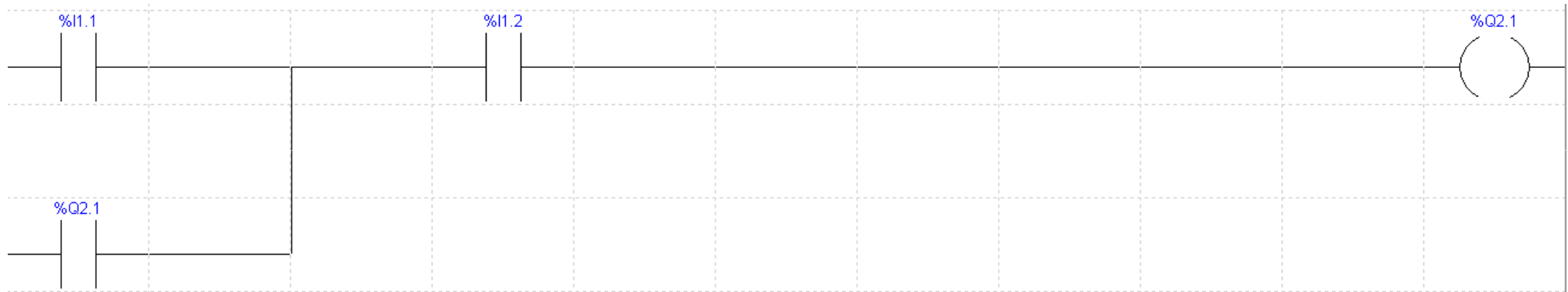

```
%Q2.1 := ( %I1.1 OR %Q2.1 ) AND %I1.2 ;
```